

Model: M300D5

Powered by MTU

Output Rating

| MODEL | | Power rating | | Voltage available |
|--------|-----------|--------------|------------|----------------------------|
| | | PRIME(1) | STANDBY(2) | |
| M300D5 | 400V/50HZ | 220KW | 240KW | 380/220V 400/230V 415/240V |
| | PF:0.8 | 275KVA | 300KVA | |

General Information

| | | |
|------------------------|------------------|-------|
| Model | M300D5 | |
| Engine | 6R1600G10F | |
| Speed control type | ADEC | |
| Phase | 3 | |
| Control System | Digital | |
| System voltage | 24V | |
| Frequency | 50HZ | |
| Engine Speed(RPM) | 1500 | |
| Fuel Consumption (L/h) | Standby power(2) | N/A |
| | Prime Power(1) | 59.35 |
| | 75% prime power | 46.69 |
| | 50% prime power | 34.17 |

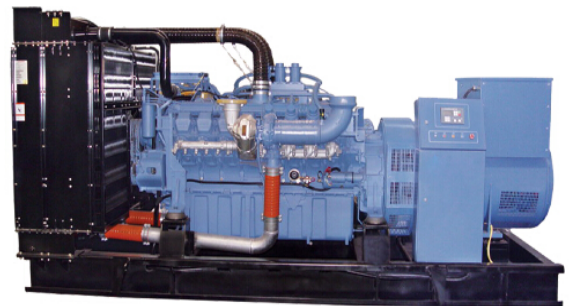

Dimension and Weight

| Dimension | Open | Silent |
|------------|--------|--------|
| Length (L) | 3000mm | 3980mm |
| Width (W) | 1335mm | 1420mm |
| Height (H) | 1880mm | 2050mm |
| Net Weight | 2795KG | N/A |

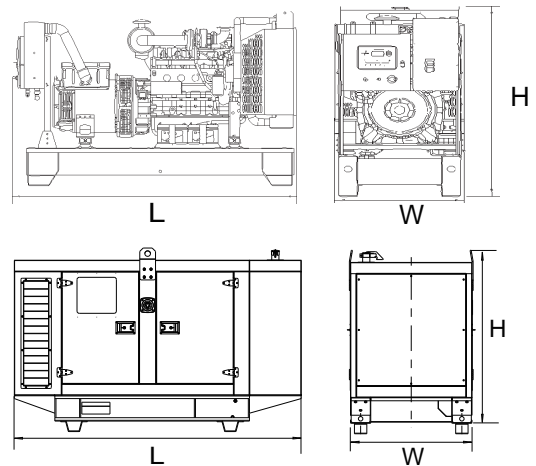

AGG POWER gensets are compliant with EC mark which include the following directives:

- * 2006/42/EC Machinery safety.
- * 2006/95/EC Low voltage
- * EN 60204-1: 2006+A1:2009, EN ISO 12100:2010, EN ISO 13849-1: 2008, EN 12601: 2010

(1) Prime Power (PRP):

According to ISO 8528-1:2005, Prime power is the maximum power which a generating set is capable of delivering continuously whilst supplying a variable electrical load when operated for an unlimited number of hours per year under the agreed operation conditions with the maintenance intervals and procedures being carried out as prescribed by the manufacturer. The permissible average power output (Ppp) over 24h of operation shall not exceed 70% of the PRP.

(2) Standby Power (ESP):

According to ISO 8528-1:2005, standby power is the maximum power available during a variable electrical power sequence, under the stated operation conditions, for which a generating set is capable of delivering in the event of a utility power outage or under test conditions for up to 200h of operation per year with the maintenance intervals and procedures being carried out as prescribed by the manufacturers. The permissible average power output over 24h of operation shall not exceed 70% of the ESP.



Engine Specification

BASIC TECHNICAL DATA

Operating method-----Four stroke Diesel
 Combustion system-----Direction Injection
 Bore/Stroke-----122/150mm
 Displacement, Total-----10.5Liter
 Number of cylinders-----4
 Compression ratio-----17.5:1
 Flywheel housing flange-----SAE 01
 Flywheel interface-----14"
 Number of intercooler-----N/A
 Number of Turbocharger-----2

STARTER SYSTEM

Starter, rated voltage-----24V
 Starter, rated requirement max-----800A
 Starter, power requirement at firing speed-----250A

COOLANT SYSTEM

Coolant temperature(at engine outlet to cooking equipment)-----95 °C
 Coolant temperature after engine, alarm-----105 °C
 Coolant temperature after engine, shutdown-----109 °C
 Coolant antifreeze content, max. permissible-----50%
 Cooling equipment: coolant flow rate-----23.3 m³/h
 Coolant pump: inlet pressure, min-----1.4bar
 Coolant pump: inlet pressure, max-----3.50bar
 Pressure loss in off-engine cooling system, max. permissible-----0.7bar
 Cooling equipment: height above engine max. permissible-----15.0m
 Cooling equipment: design pressure-----N/A

Recommended coolant:
 Recommended coolant: 50% anti freeze / 50% water. For complete details of recommended coolant specifications, refer to the Operation and Maintenance Manual for this engine model.

COMBUSTION AIR

Combustion air volume flow-----0.45m³/sec
 Intake air depression-----230mbar

FUEL SYSTEM

Fuel supply flow, max.-----5.7l/min
 Fuel temperature, max.-----55 °C
 Fuel pressure at supply connection on engine, max. admissible-----+2.0 bar
 Fuel pressure at supply connection on engine, min. admissible----- -0.1 bar

FUEL SPECIFICATION

USA Fed Off Highway - EPA2D 89.330-96
 Europe Off Highway - CEC RF-06-99
 Note: For further information on fuel specifications and restrictions, refer to the OMM Fuels section for this engine model.

FUEL CONSUMPTION

| Power rating % | | | |
|----------------|-------|-------|-------|
| L/h | | | |
| 110 | 100 | 75 | 50 |
| N/A | 59.35 | 46.69 | 34.17 |

EXHAUST SYSTEM

Exhaust volume flow-----0.93m³/sec
 Exhaust temperature after turbocharger-----490 °C
 Exhaust backpressure limit value-----15mbar

HEAT DISSIPATION

Engine coolant dissipation 100% load-----210kw
 Charge-air heat dissipation 100% load-----47kw
 Radiation and convection heat, engine-----21kw



▪ Alternator

| Alternator | | |
|--------------------------------|-------|--------------------------------|
| Poles | Num | 4 |
| Winding Connections (standard) | | Star-serie |
| Insulation | Class | H class |
| Enclosure (according IEC-34-5) | | IP23 |
| Exciter System | | Brushless |
| Voltage Regulator | | A.V.R. (Electronic) |
| Bearing | | Single bearing |
| Coupling | | Flexible disc |
| Coating type | | Standard (Vacuum impregnation) |

▪ Options

| Engine | Alternator | Generator Sets | Fuel System | Canopy |
|---|--|--|---|--|
| <ul style="list-style-type: none"> •Water Jacket Preheater •Oil Preheater | <ul style="list-style-type: none"> •Winding Temperature measuring Instrument •Alternator Preheater •PMG •Anti-damp and anti-corrosion treatment •Anti-condensation heater | <ul style="list-style-type: none"> •Tools with the machine | <ul style="list-style-type: none"> • Low fuel level alarm •Automatic fuel feeding system •Fuel T-valves | <ul style="list-style-type: none"> •Rental Type Canopy •Trailer |
| Lubricating System | Exhaust System | Cooling System | Control Panel | Voltages |
| <ul style="list-style-type: none"> •Oil with the machine | <ul style="list-style-type: none"> •Protection board from hotness | <ul style="list-style-type: none"> • Front heat protection • Coolant (-30°C) | <ul style="list-style-type: none"> •Remote control panel • ATS • Remote controller • Synchronizing controller | <ul style="list-style-type: none"> • 415/240V • 380/220V • 220/127V • 220/127V • 200-115V |



Control Panel



Product description

- Single gen-set controller for Stand-by and Prime-power applications
- Direct communication with EFI engines
- Total remote monitoring and control

Key features

- Easy to install, configure and use
- Wide range of communication capabilities including:
 - connection via RS232, RS485, CAN and on board USB
 - internet access using Ethernet or GPRS
 - support for Modbus and SNMP protocols
- Cloud-based monitoring and control
- Active SMS and emails in different languages
- 2x 5 A binary outputs for cranking and fuel solenoid
- Option for up to 16 additional binary inputs/outputs
- Flexible event based history with up to 350 events
- Load shedding, dummy load capability
- Automatic temperature based cooling/heating
- Comprehensive gen-set protections
- Multipurpose flexible timers
- True RMS measurement

Available extension modules

| Product | Description | Order code |
|--------------|------------------------------------|-------------|
| CM-Ethernet | Ethernet interface | CM2ETHERXBX |
| CM-GPRS | GSM modem / wireless internet | CM2GPRSXXBX |
| CM-RS232-485 | Dual port interface | CM223248XBX |
| EM-BIO8-EFCP | 8 additional binary inputs/outputs | EM2BIO8EXBX |

Functions and protections

| Description | ANSI code | Description | ANSI code |
|--|-----------|---------------------|-----------|
| Over voltage | 59 | Load shedding | 32P |
| Under voltage | 27 | Overload | 32 |
| Voltage asymmetry and Phase rotation** | 47 | Power factor | 55 |
| Over frequency | 81H | Temperature | 49T |
| Under frequency | 81L | Gas (fuel) level | 71 |
| Over current* | 50 + 51 | Earth fault current | 50N + 64 |
| Current unbalance | 46 | | |

* Short current only

** Fixed setting

